

**UNDER BENCH HEAVY DUTY
COMMERCIAL DISH WASHER**

Washes approximately
500 plates per hour.

SSS-500



Sharpline 

Australian made – Australian owned

UNDER BENCH HEAVY DUTY COMMERCIAL DISH WASHER SSS-500



The Sharpline SSS-500 is a fully automatic front loading commercial dishwasher designed for under bench installation, with a capacity to wash 500 plates per hour.

Features of the SSS-500 include:

Two wash programs of 120 and 180 seconds each, which includes a 10 second rinse cycle.

A large door opening enables the machine to wash plates up to 320 mm in diameter.

Rotating upper and lower wash and rinse arms ensure that the maximum pressure reaches all surfaces.

Rounded washing compartment allows easy cleaning.

Water consumption is approximately 2.7 litres per cycle.

The SSS-500 operates on single phase power and is supplied with a cable and 15 amp plug.

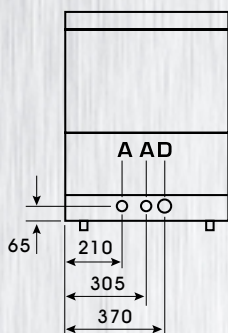
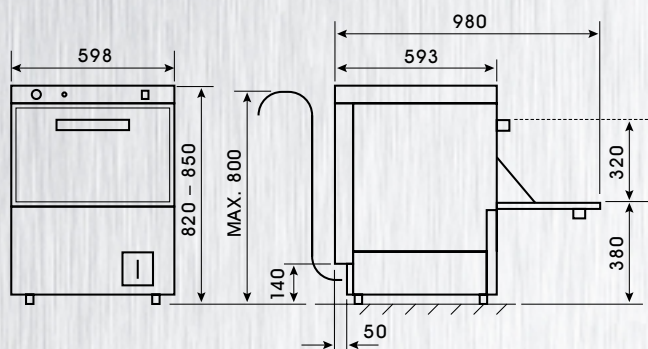

Connection Points

- A** Electrical connection 15 Amp 240 V
- B** Water inlet 3/4" B.S.P. at 60 ° C
- C** Drain 30 mm

*For further information visit our web site!
www.sharpline.com.au*

Sharpline



Australian made – Australian owned

700 Sydney Road (Cnr Gaffney Street)
Coburg Victoria Australia 3058
Phone 03 9354 0277 Fax 03 9354 0278
Email: sharpline@sharpline.com.au
www.sharpline.com.au

STAINLESS STEEL PTY LTD

ABN 95 880 037 140

Specifications subject to change without notice

Design/Production: Roman Zylinski advertising Services. 03 9561 9957. roman.zylinski@bigpond.com